

**HUMBOLDT COUNTY BUILDING DEPARTMENT
CITY OF WINNEMUCCA BUILDING DEPARTMENT
STAIRWAY & LANDING REQUIREMENTS FOR COMMERCIAL BUILDINGS, MODULAR BUILDINGS
AND COMMERCIAL COACHES**

Construction materials of stairs and guardrails shall be structurally sound, noncombustible where required, and rot resistant and weather resistant. All spans of construction material shall comply with the IBC. Connection of material, handrails and guardrails shall support loads as required by the IBC. Exterior stairways shall not be placed within 10 feet of a property line. IBC Section 1023.3

FLOOR LEVEL AT DOORS – IBC SECTION 1008.1.4

Regardless of the occupant load, there shall be a floor or landing on each side of the door. Such floor or landing shall be at the same elevation on each side of the door. Thresholds at doorways shall not exceed $\frac{1}{2}$ ".

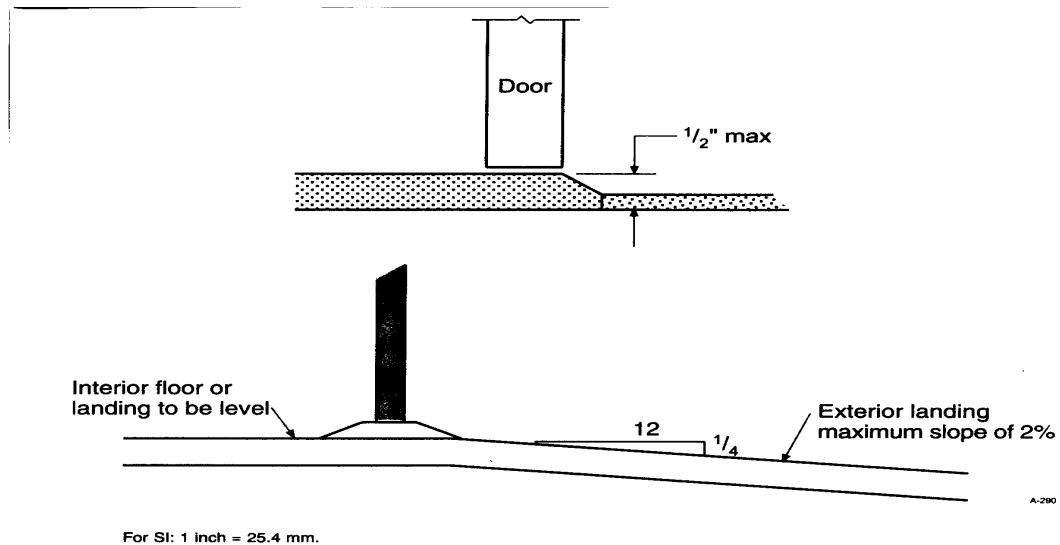

For interior situations, landings should be level. In exterior applications, landings may have a slope not to exceed $\frac{1}{4}$ unit vertical in 12 units horizontal (1:48). This maximum slope of 2% provides a relatively flat surface while maintaining adequate drainage.

WIDTH AND HEIGHT OF STAIRWAYS – IBC SECTION 1009.1 & 1009.2

Stairways serving an **occupant load of 50 or less** shall not be less than **36" in width**. Projections into the required width at each handrail shall not exceed 4 1/2' at or below handrail height. Stairways shall have a minimum headroom clearance of 80" measured vertically from a line connecting the edge of the nosings. Such headroom shall be continuous above the stairway to the point where the line intersects the landing below, one tread depth beyond the bottom riser. The minimum clearance shall be maintained the full width of the stairway and landing.

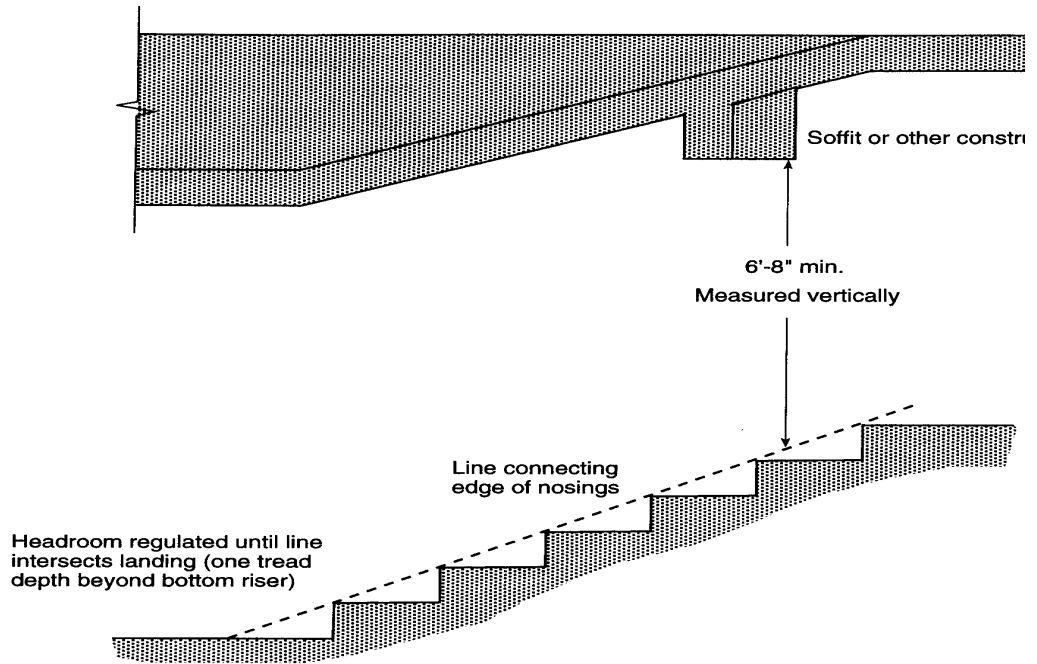

RISE AND RUN OF STAIRWAYS – IBC SECTION 1009.3

Stair **risers** height shall be **7" maximum and 4" minimum**. The stair **tread depth** shall be **11" minimum**. The largest tread run within any flight of stairs shall not exceed the smallest by more than 3/8". The greatest riser height within any flight of stairs shall not exceed the smallest by more than 3/8".

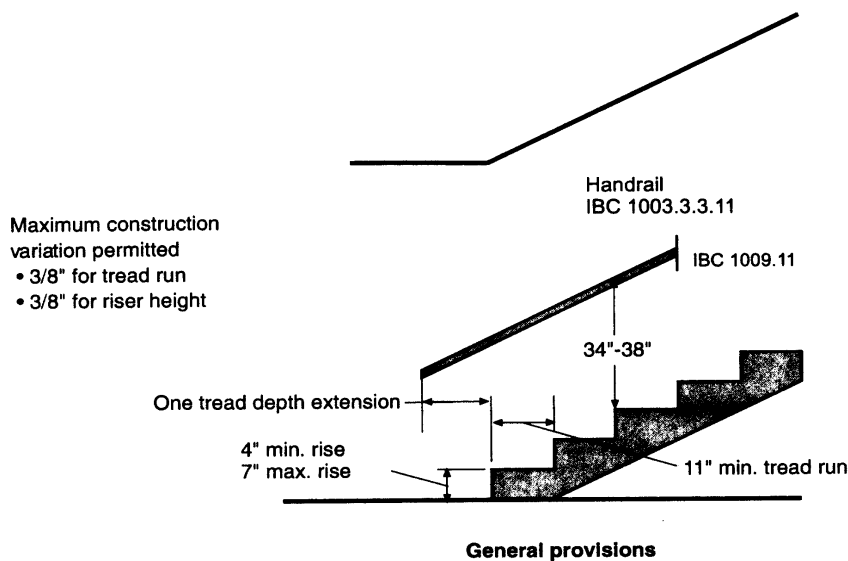

LANDING AT STAIRWAYS – IBC SECTION 1009.4 & SECTION 1009.6

There shall be a floor or landing at the top and bottom of each stairway. The width of the landing shall not be less than the width of the stairways they serve. Every landing shall have a minimum dimension measured in the direction of travel equal to the width of the stairway. Such dimension need not exceed a 48" where the stairway has a straight run. **A flight of stairs shall not have a vertical rise greater than 12 feet between floor levels or landings.**

1009.4 Stairway Landings

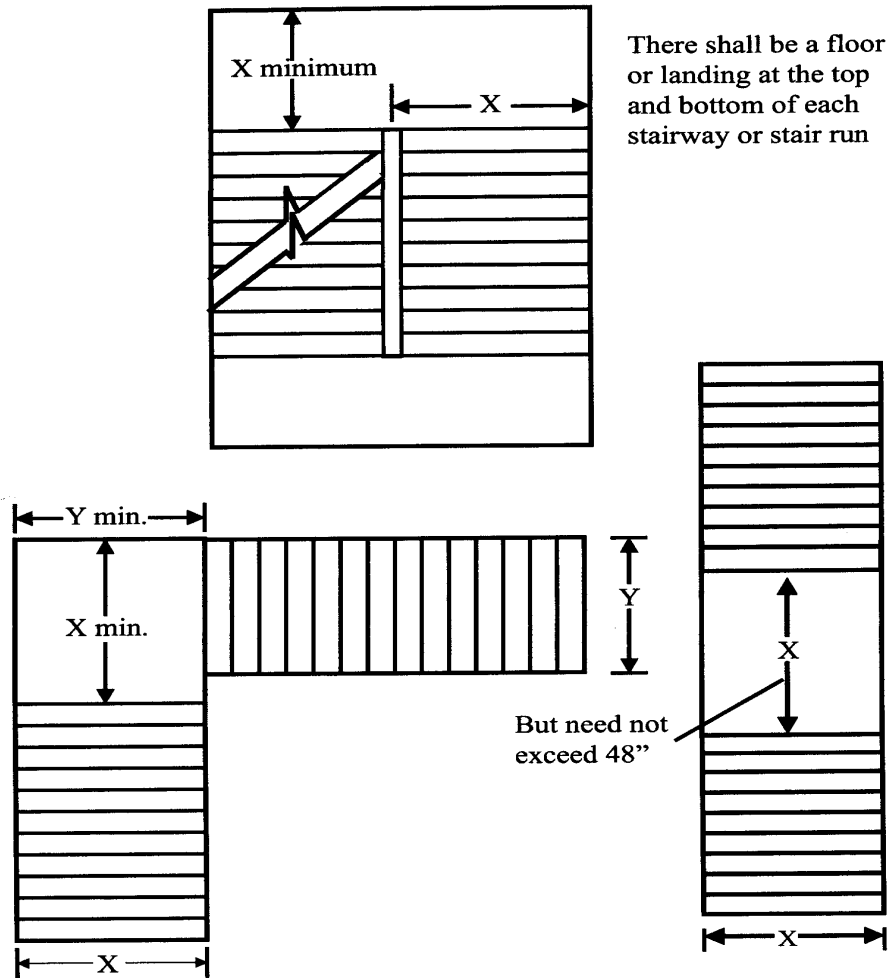

HANDRAILS – IBC SECTION 1009.11

Stairways shall have handrails on each side. The top of the handrails and handrail extensions shall be placed not less than **34" or more than 38"** above the nosing treads and landings. Handrails with a circular cross section shall have an outside diameter of **at least 1.25" and not greater than 2"** or shall provide equivalent graspability. If handrail is not circular, it shall have a perimeter dimension of at least 4" and not greater than 6.25" with a maximum cross section dimension of 2.25". Handrail gripping surfaces shall be continuous, without interruption by newel posts or other obstructions. Handrails shall return to a wall, guard, or walking surface or shall be continuous to the handrail of an adjacent stair flight. **Handrails shall extend 12" beyond the top riser and one tread beyond the bottom riser.**

Section 1009.11.3

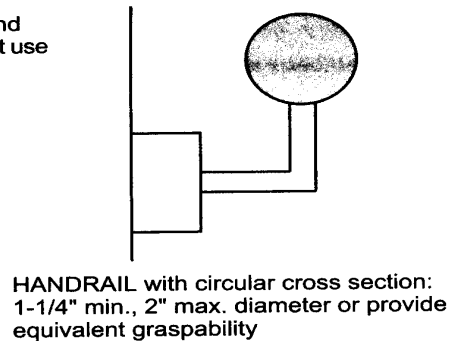
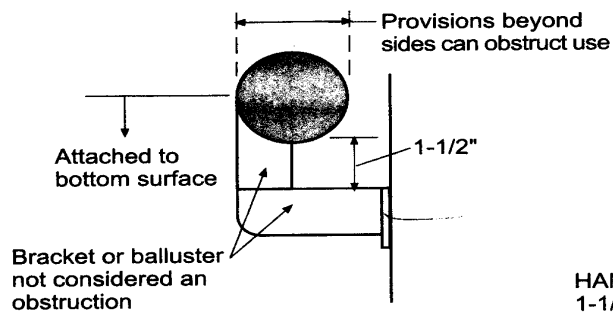

Section 1009.11.6

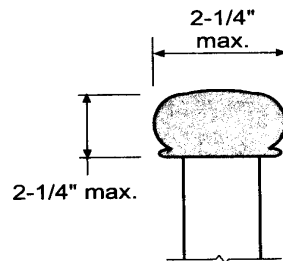
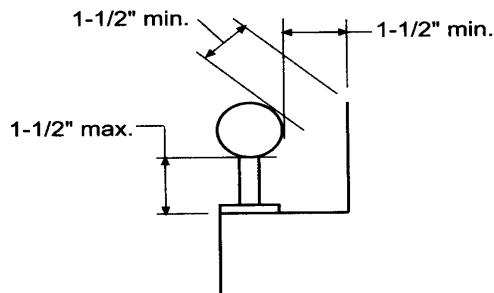

HANDRAIL that is not circular:
perimeter of at least 4" but not greater than 6-1/4"

A-300

For SI: 1 inch = 25.4 mm.

A major goal of handrail design and location is to make it easily graspable; hence, it is mandatory that the rail be placed at least 1 1/2 inches from any abutting elements, such as a wall. However, the projection of the rail into the required width is limited to no more than 4 1/2 inches.

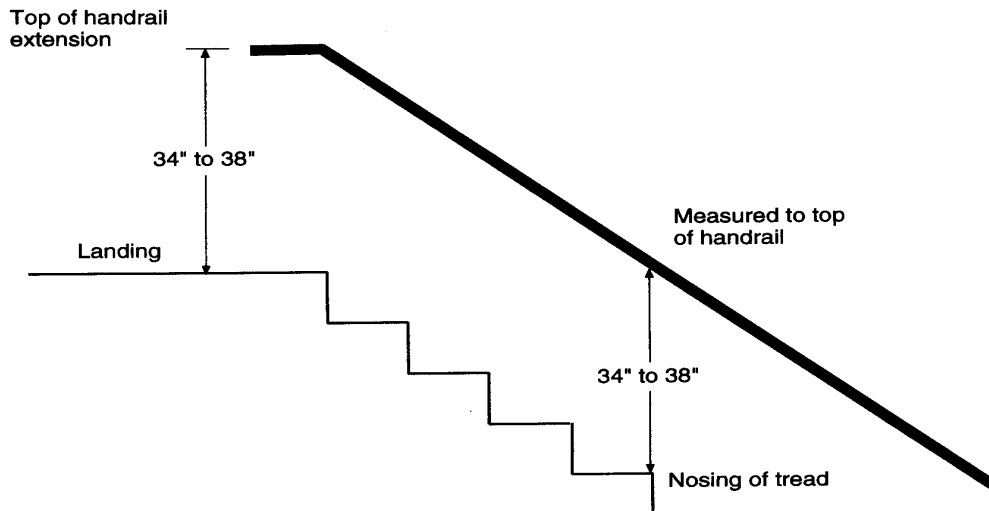

GUARDS – IBC SECTION 1012

Guards shall be located along open-sided walking surfaces, mezzanines, industrial equipment platforms, stairways, ramps and landings which are located more than 30" above the floor or grade. **Guards shall be a minimum height of 42"**.

Open guards shall have balusters or ornamental patterns such that a 4" diameter sphere cannot pass through any opening up to a height of 34". From a height of 34" to 42" above the adjacent walking surface a sphere 8" in diameter shall not pass.

Industrial and storage occupancies with no public access may increase opening per the Building Official's approval on IBC Section 1012.3 requirements.

